



12 Clintonville Road
Northford, CT 06472-1653 USA
203-484-7161 • FAX 203-484-7118
www.notifier.com

Network Communications Module NCM-W/F Product Installation Document

PN 51533:D2 04/13/2012 ECN 12-0105

1 UL 864 Compliance

1.1 Products Subject to AHJ Approval

This product has been certified to comply with the requirements in the Standard for Control Units and Accessories for Fire Alarm Systems, UL 864 9th Edition.

The following products have not received UL 864 9th Edition certification and may only be used in retrofit applications. Operation of the NCM-W, NCM-F with products not tested for UL 864 9th Edition has not been evaluated and may not comply with NFPA 72 and/or the latest edition of UL 864. These applications will require the approval of the local Authority Having Jurisdiction (AHJ).

- AM2020/AFP1010
- MIB
- NAM-232

2 Product Overview

The Network Communications Module (NCM) provides a means for connecting specific Notifier fire alarm control products to **NOTI•FIRE•NET™**. There are two types of NCMs available: NCM-W for connecting nodes with twisted-pair wire, and NCM-F for connecting nodes with fiber-optic cable.

In most applications, one NCM is required per **NOTI•FIRE•NET™** node (including fire alarm control panels and network annunciators). Even though the NCM has two NUP ports, only one may be connected to a **NOTI•FIRE•NET™** node. Except in some DVC applications, do not connect two NCMs via NUP ports (aka “NUP to NUP”).

For instructions on the additional capabilities available with the DVC, refer to the *DVC Manual*.

- Input power requirements: 24 VDC, 0.11 amps, regulated, power-limited compatible power supply UL/ULC listed for fire protective signalling use.
- Communications circuit requirements: Refer to the **NOTI•FIRE•NET™ Manual (Network Version 4.0 and Higher)** for wiring length and threshold information.

2.1 The Network Communications Module for Wire (NCM-W)

- Supports twisted-pair wire medium.
- NFPA Style 4 (Class B) operation or NFPA Style 7 (Class A) operation.
- Two programmable data thresholds.
- Transformer coupling provides electrical isolation between nodes.
- Pluggable terminal wiring with strain relief.
- Pluggable service connector (feeds signal directly through) in the event that power must be removed from a node.
- 312.5 Kbaud transmission rate.
- Data is regenerated at each node.
- Two network ports to allow simultaneous connection to fire alarm control panel and to programming computer
- Enables software and database upload/download over **NOTI•FIRE•NET™**.
- Refer to the **NOTI•FIRE•NET™ Manual (Network Version 4.0 and Higher)** for wiring length and threshold information.

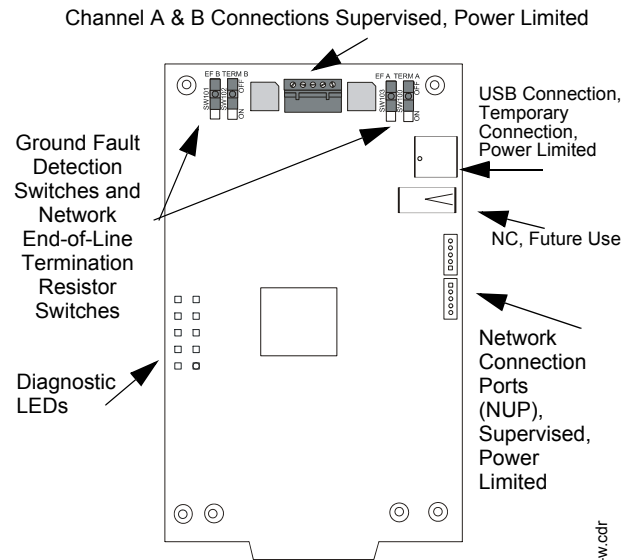

Figure 1 NCM-W

2.2 The Network Communications Module for Fiber (NCM-F)

- Supports fiber-optic medium.
- NFPA Style 4 (Class B) or Style 7 (Class A) operation.
- Data is immune to all environmental noise.
- Optical isolation prevents ground loops.
- **NOTI•FIRE•NET™** fiber optic medium.
- Fiber type:
 - 62.5/125 micrometers (multimode, 8 dB limit)
 - 50/125 micrometers (multimode, 4.2 dB limit)
- Wavelength (1): 820 nanometers. (Use standard 850 nm fiber.)
- Connectors: ST® Style (ST® is a registered trademark of AT&T).
- 312.5 Kbaud transmission rate.
- Data is regenerated at each node.
- Two network ports to allow simultaneous connection to fire alarm control panel and to programming computer.
- Enables software and database upload/download over **NOTI•FIRE•NET™**.

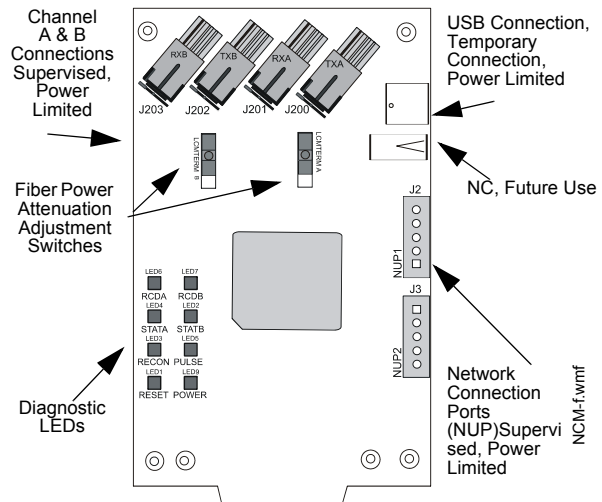

Figure 2 NCM-F

3 Installation

3.1 Mounting Options

The NCM-W/NCM-F is designed to mount in a variety of CAB-3/CAB-4 -compatible chassis, in the NFS-320 enclosure, on a BMP-1 blank plate for dress panel mounting, or behind the DVC in the CA-1 or CA-2 audio chassis. NCM-W can be door-mounted; NCM-F must be installed in a stationary location. Recommended location is in the top row under the backbox's knockout, so as to avoid over-bending fiber-optic cable. Avoid mounting other option boards in front of NCM so that its LEDs are visible. Attach the NCM-W/F to its mounting hardware using the four screws that ship with it.

Cabinet-mounting NCM-W/NCM-F:

- CHS-4/4L/4N, CHS2-M2, CHS2-M3, CHS-M3, or NFS-320 enclosure: Mount the NCM in standard option module positions as described in your control panel installation manual. Figure 3 shows CHS-4L as an example.
- CA-1, CA-2: Mount the NCM-W/F behind a DVC in either the CA-1 or CA-2 audio chassis. Figure 4 illustrates how to install it in a CA-1. Mounting is the same behind a DVC in the lower half-chassis of a CA-2.

Door-mounting NCM-W:

- Door-mount on the ADP-4B Dress Panel on a single-space blank plate (BMP-1) for mounting in a CAB-4 series backbox, as described in Figure 5.

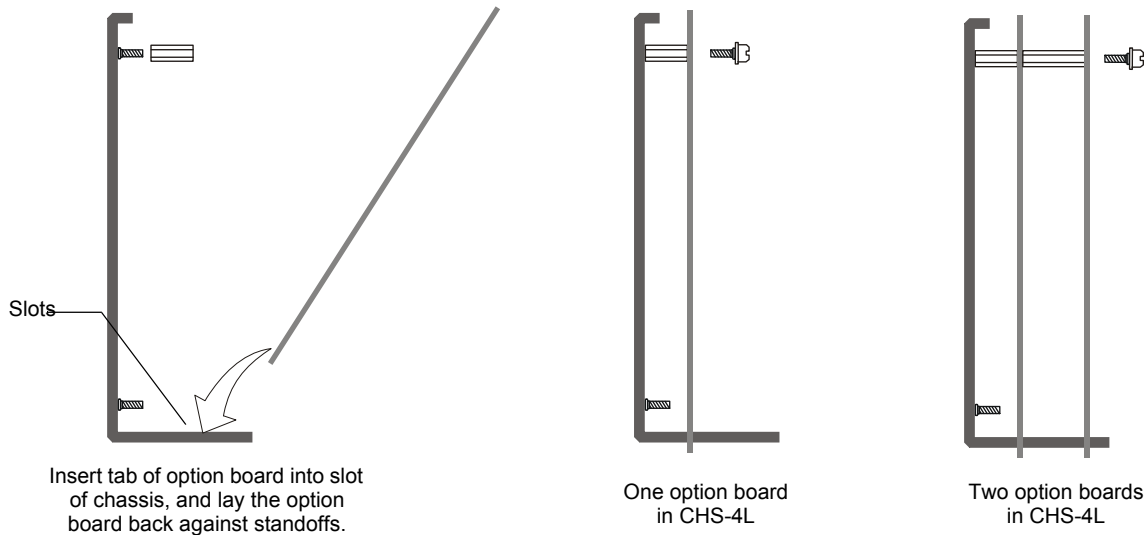

Figure 3 Mounting NCM in a Chassis (CHS-4L Shown)

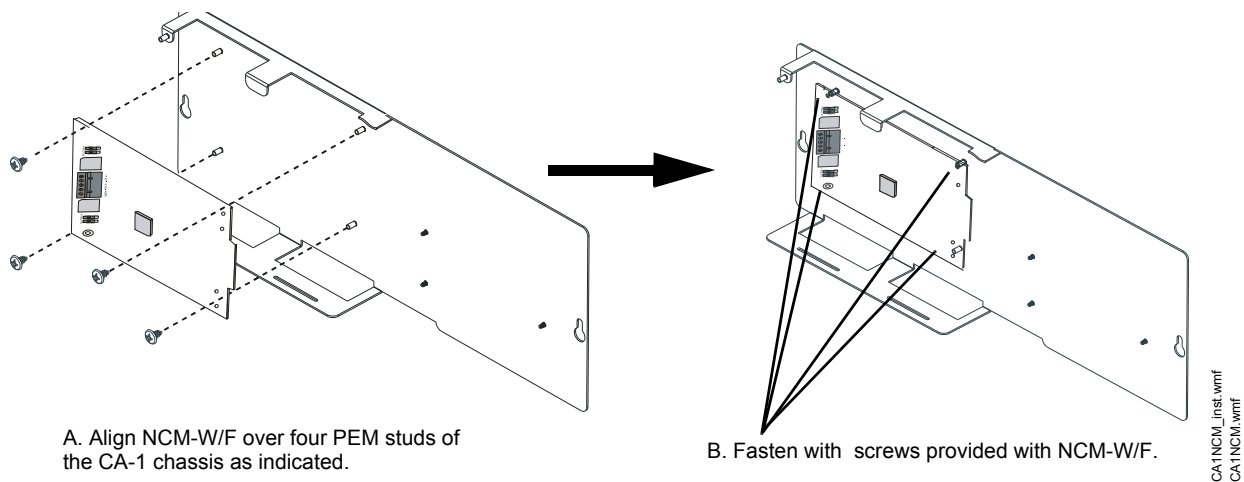
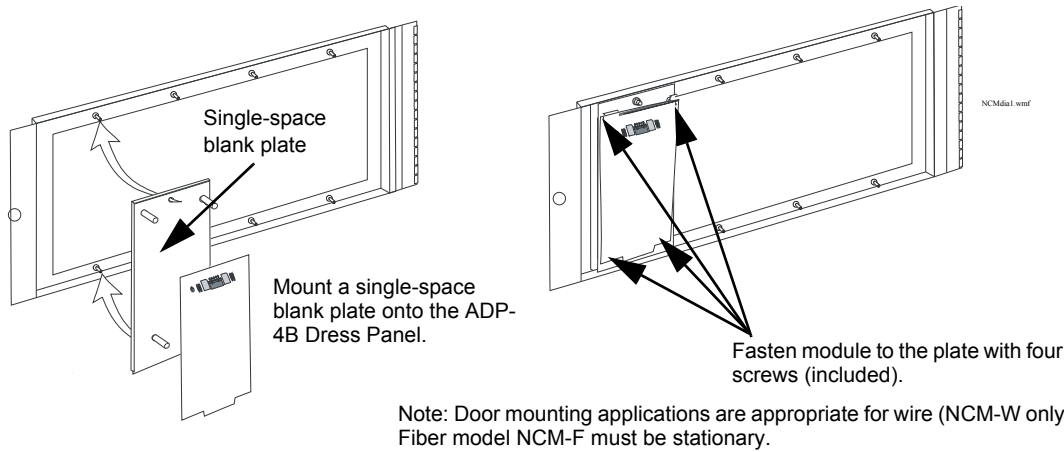

Figure 4 Installing an NCM-W/F onto the CA-1 or CA-2 Audio Chassis Assembly



NOTE: The module cannot be mounted in the ADP-4B Dress Panel when a front slot of the CHS-4 or CHS-4N is occupied, or when either of the two front right positions of the CHS-M2 is occupied. Always be certain there is enough clearance to close the cabinet door when this installation is used.

Figure 5 Door-Mounting the NCM-W

3.2 Interconnecting the NCM-W

When wiring consecutive NCM-W boards, note that wiring may enter or exit at Port A or Port B as shown in Figure 6. NCM-W port-to-port wiring is not polarity sensitive. The use of Port A or Port B is arbitrary. An NCM-W may be connected to any of the following devices:

- NCM-W (in another panel)
- NCS-W network connection
- RPT-W
- RPT-WF
- NFN-GW-PC-W (included with ONYXWORKS-NW)

For information regarding these devices, refer to the documentation listed in Table 4 “Supplemental Documentation”.

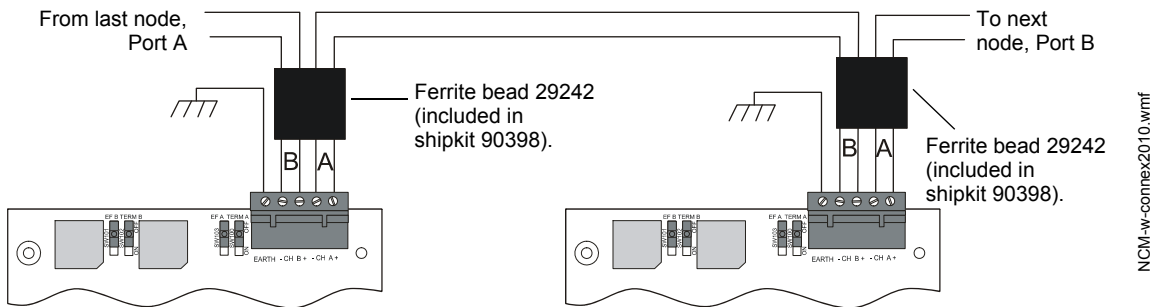

Figure 6 The NCM-W

- Please note that for FCC compliance, the specified ferrite bead must be installed on the network wiring entering/leaving the NCM-W. Snap the ferrite bead around the two wires (Style 4) or four wires (Style 7) approximately 0.5” - 0.75” from the connector. Secure using tie wraps.
- Please note that wiring from the NCM-W that is installed outside the building:
 - Cannot exceed 1000m (3280 ft.).
 - Must be in conduit and is to be buried in a trench separate from any power lines.
 - Cannot cross any power lines.

TB100-1	CH-A (+)	Channel-A Driver/Receiver
TB100-2	CH-A (-)	Channel-A Driver/Receiver
TB100-3	CH-B (+)	Channel-B Driver/Receiver
TB100-4	CH-B (-)	Channel-B Driver/Receiver
TB100-5	Earth Ground	

Table 1 NOTI•FIRE•NET™ Connections: NCM-W

■ **Switch Functions: Ground Fault Detection and Line Termination**

The NCM-W provides two sets of switches to simplify network setup; in Figure 7 all are in the “off” position.

- For UL 864 applications, enable ground fault detection by setting EF switches “on”: SW103 for Channel A, and SW101 for Channel B.
- Activate on-board end-of-line resistors by setting TERM switches “on”: SW100 for Channel A; SW102 for Channel B.
- Zero Ohms to ground will cause a ground fault.

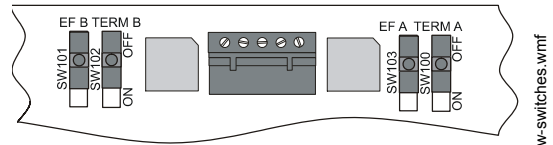

Figure 7 NCM-W Switches

Correct configuration depends on your network design; for an explanation of design concepts, refer to the **NOTI•FIRE•NET™ Manual (Network Version 4.0 and Higher)**.



NOTE: The NCM-W does not indicate ground faults; it enables its +24V power supply to detect and indicate ground faults.



NOTE: Ground fault detection **must** be enabled for UL 864 applications and for ULC applications.

3.3 Interconnecting the NCM-F

When connecting consecutive nodes/repeaters, note that fiber cable must exit one board on transmit (TX) and enter the next node/repeater on receive (RX). Also, note that the fiber-optic pair (RX, TX) from port A of one Node/Repeater may be connected to either Port A or Port B of another node/repeater (refer to Figure 8). An NCM-F may be connected to any of the following devices:

- Another NCM-F
- Network connection for NCS-F
- RPT-F
- RPT-WF
- NFN-GW-PC-F (included with ONYXWORKS-NF)

For information regarding these devices, refer to the documentation listed in Table 4 “Supplemental Documentation”.



NOTE: See the **NOTI•FIRE•NET™ Manual (Network Version 4.0 and Higher)** for maximum fiber-optic cable attenuation.

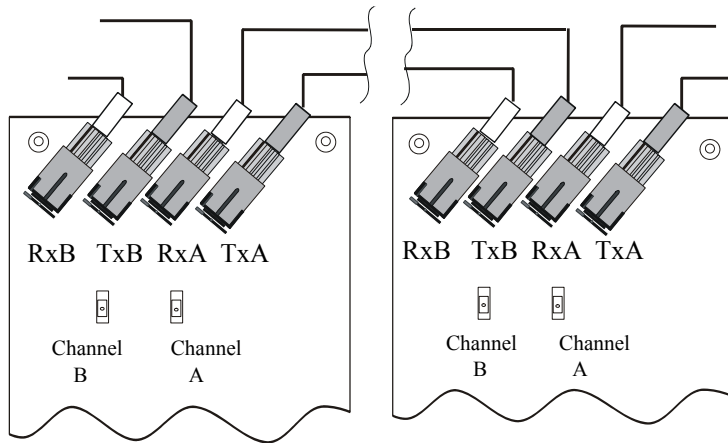

Figure 8 NCM-F Connection

3.4 Switch Functions: Fiber Power

The NCM-F provides a set of switches to attempt to resolve any issues that might arise with back reflections or signal overdriving.

- For default configuration, leave the switches set to “full” for normal signal power.
- If an issue arises with a short distance of fiber or low dB loss, set the switch to “low.”

J200	CH A	Transmit
J201	CH A	Receive
J202	CH B	Transmit
J203	CH B	Receive

Table 2 NOTI•FIRE•NET™ Connections: NCM-F

3.5 Mixing Wire & Fiber on One Network

In some networks, it may be necessary to mix twisted-pair wire and fiber-optic cable—use an RPT-WF as an interface between wire and fire. Under UL 8th edition, networks using AM2020/AFP1010 used a MIB-WF as the interface between wire and fiber.

See Section 2.2, “The Network Communications Module for Fiber (NCM-F)” for requirements and restrictions on the use of fiber optic cable. See the **NOTI•FIRE•NET™ Manual (Network Version 4.0 and Higher)** for a discussion of all compatible configurations.

4 Diagnostic Indicators

The NCM has LEDs that serve as diagnostic indicators to help in troubleshooting and system connection. Refer to Table 3 for a list of diagnostic indicators and their descriptions. Refer to Figure 9 for location of the diagnostic indicators.

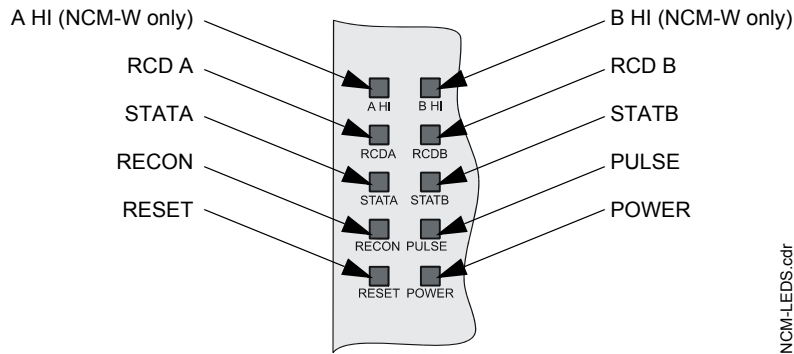

Figure 9 Diagnostic Indicator Locations

LED Indicator	LED Color	LED Description
A HI (NCM-W only)	Green	Illuminates to indicate the NCM-W Port A is set for high threshold.
B HI (NCM-W only)	Green	Illuminates to indicate the NCM-W Port B is set for high threshold.
RCD A	Green	Illuminates when the NCM is receiving data from NOTI•FIRE•NET™ on Port A.
RCD B	Green	Illuminates when the NCM is receiving data from NOTI•FIRE•NET™ on Port B.
STATA	Yellow	Illuminates when the NCM has not received valid data from NOTI•FIRE•NET™ on Port A for at least 16 seconds.
STATB	Yellow	Illuminates when the NCM has not received valid data from NOTI•FIRE•NET™ on Port B for at least 16 seconds.
RECON	Yellow	Illuminates when a reconfiguration on NOTI•FIRE•NET™ is in progress.
PULSE	Green	Illuminates when the NCM is transmitting data to NOTI•FIRE•NET™ .
RESET	Yellow	Illuminates when the microcontroller fails.
POWER	Green	Illuminates when +5 VDC is available

Table 3 Diagnostic Indicator Functions and Colors

5 Supplemental Documentation

The table below provides a list of document sources (manuals) containing additional information regarding the NCM-W/F and the **NOTI•FIRE•NET™** products that it can connect to.

For information on...	Refer to...	Part No.
Fire Alarm Control Panels (FACPs) and Networking	NOTI•FIRE•NET™ Manual (for Network Version 4.0 and Higher)	51584
	Onyx NCS Network Control Station (for Network Version 4.0 and Higher)	51658
	NCS Network Control Station (for Network Version 4.0)	51585
	NCA Network Control Annunciator	51482
	NCA-2 Network Control Annunciator	52482
	ONYXWorks	50255
	Media Interface Board (MIB) Manual	50038
	NAM-232 Network Adaptor Module	50256
	RPT - W/WF/F Repeaters for NOTI•FIRE•NET™	
	NFS2-640 Installation	52741
	Operations	52743
	Programming	52742
	NFS-320 Installation	52745
	Operations	52747
	Programming	52746
NFS-640 Installation	51332	
Operations	51333	
Programming	51334	
NFS-3030 Installation	51330	
Operations	51345	
Programming	51344	
NFS2-3030 Installation	52544	
Operations	52545	
Programming	52546	
	ONYXWorks™ Workstation Hardware & Software Application: Installation and Operation Manual	52342
	ONYXWorks™ NFN Gateway (PC Platform) Installation & Operation Manual	52307
	ONYXWorks™ NFN Gateway (Embedded Platform) Installation & Operation Manual	52306
Off-line Programming Utility	VeriFire™ Tools CD on-line help file	VeriFire-TCD
Compatible Devices	Device Compatibility Document	15378
Cabinets & Chassis	CAB-3/CAB-4 Series Installation Document	15330
	CA-2 Audio Chassis Installation Document	52455
	BMP-1 Product Installation Document	51119
	Also see your panel's Installation Manual	

Table 4 Supplemental Documentation



NOTE: For module mounting instructions, refer to the documentation for your control panel.